

LOLA

classic
kitchen collection



ARREX
LE CUCINE

Con Arrex siete liberi, sempre.

In una cucina Arrex la libertà ha tante forme: la libertà di progettare lo spazio; la libertà di scegliere finiture, materiali e colori; la libertà di comporre con moduli, elementi e dettagli; la libertà di personalizzare misure, aperture e particolari; la libertà di muovere oggetti ed ingredienti; la libertà di esprimere il proprio stile di arredo. Con Arrex siete liberi di creare la cucina dei vostri desideri, per viverla in ogni sua forma e dividerla con le persone che amate.

With Arrex you're free, always.

In an Arrex kitchen, freedom takes on many forms: freedom to design your space; freedom to choose finishes, materials and colours; freedom to build your own compositions with modules, elements and accessories; freedom to customise sizes, openings and details; freedom to move objects and ingredients around; and freedom to express your own furnishing style. With Arrex, you are free to create the kitchen of your dreams, enjoy it in all its forms and share it with the people you love.

Avec Arrex vous êtes libres, toujours.

Dans une cuisine Arrex la liberté a de nombreuses formes : la liberté de concevoir l'espace ; la liberté de choisir les finitions, les matériaux et les coloris ; la liberté de composer avec des modules, des éléments et des détails ; la liberté de personnaliser les dimensions, les ouvertures et les particularités ; la liberté de déplacer les objets et les ingrédients ; la liberté d'exprimer son propre style d'ameublement. Avec Arrex vous êtes libres de créer la cuisine que vous souhaitez, pour la vivre dans chacune de ses formes et la partager avec les personnes que vous aimez.

Con Arrex siempre tendrás libertad.

En una cocina Arrex, la libertad toma muchas formas: la libertad de diseñar el espacio; la libertad de elegir acabados, materiales y colores; la libertad de componer con módulos, elementos y detalles; la libertad de personalizar medidas, aperturas y pormenores; la libertad de mover objetos e ingredientes; la libertad de expresar el estilo decorativo personal. Con Arrex serás libre de crear la cocina de tus sueños, para disfrutarla en todas sus formas y compartirla con las personas que amas.

LIBERTÀ IN CUCINA

ARREX
LE CUCINE

Lola è la cucina dove ingredienti come l'anta bugnata in frassino decapé danno vita a ricette inedite, creando uno spazio in cui essere liberi di scegliere e di comporre.

In the Lola kitchen, ingredients such as the moulded Décapé ash door are used to create original recipes. Be free to choose and build your composition as you like.

Lola est la cuisine où des ingrédients comme la porte bosselée en frêne décapé donnent naissance à des recettes inédites, en créant un espace où être libres de choisir et de composer.

Lola es la cocina en la que ingredientes como la puerta plafonada de fresno decapé dan vida a recetas inéditas, creando un espacio en el que se puede elegir y componer con libertad.

LOLA

classic collection



comp.

01



In cucina le venature chiare del legno di frassino si accostano al grigio scuro del top e della cappa e al bianco del lavabo. I contrasti creano un contesto armonioso.

In this kitchen, a pale ash wood grain features alongside a dark grey top and hood, and a white sink. These contrasts create a harmonious look.

En cuisine les veinures claires du frêne se juxtaposent au gris foncé du plan de travail et de la hotte et au blanc du lavabo. Les contrastes créent un contexte harmonieux.

En la cocina, las venas claras de la madera de fresno se combinan con el gris oscuro de la encimera y de la campana y con el blanco del fregadero. Los contrastes crean un contexto armonioso.





Pensili con una pratica apertura verso l'alto, per dare ad ogni cosa il suo spazio, e la cappa "Officina" in finitura antracite, per un dettaglio dal sapore industriale.

These wall units open upwards, making a practical space for all of your kitchen equipment. The dark grey Antracite hood gives the space an industrial feel.

Des éléments hauts avec une pratique ouverture vers le haut, pour donner à chaque chose sa place, et la hotte « Officina » finition antracite, pour un détail à la saveur industriel.

Muebles altos que se abren cómodamente hacia arriba, para dar a cada cosa su espacio, y la campana "Officina" en acabado antracite, para un detalle de sabor industrial.



Cappa "Officina" -> Antracite
Hood - Antracite / Hotte - Antracite / Campana - Antracite

Il tavolo, essenziale nelle linee e nella tonalità, come punto centrale della vita in cucina. Dal caffè del mattino alla tisana della sera, ogni momento è tutto da assaporare.

The table is the fulcrum of the kitchen space, with its simple lines and colour. From your morning coffee right through to a herbal tea before bed, here you can enjoy every moment.

La table, essentielle dans les lignes et les tonalités, comme point central de la vie en cuisine. Du café du matin à la tisane le soir, chaque moment est tout à savourer.

La mesa, sobria en sus líneas y tonos, como punto central de la vida en la cocina. Desde el café matutino hasta la tisana de la tarde, merece la pena saborear cada momento.

Tavolo art. B560 -> Impiallacciato
Frassino Decapé Bianco
Table - Veneered in Décapé
Bianco Ash / Table - Plaqué Frêne
Décapé Bianco / Mesa - Chapada
Fresno Decapé Bianco

Sedia art. B900 -> Frassino
Decapé Bianco
Chairs - Décapé Bianco
Ash / Chaise - Frêne Décapé Bianco /
Silla - Fresno Decapé Bianco



Sui porta mensole in metallo grigio antracite, stoviglie e ingredienti sono a vista e sempre a portata di mano. Gli oggetti in cucina sono organizzati con ordine e originalità.

These shelving frames in Grigio or Antracite metal provide space for tableware and ingredients, on show and always to hand. Organise your kitchen essentials tidily in an original way.

Sur les porte étagères en métal grigio ou antracite, la vaisselle et les ingrédients sont visibles et toujours à portée de main. Les objets en cuisine sont organisés avec ordre et originalité.

En las estructuras de estantería de metal grigio o antracite, la vajilla y los ingredientes están a la vista y siempre a mano. Los objetos de la cocina están organizados con orden y originalidad.

Porta mensole "Double" -> Metallo Antracite
Shelving frame - Antracite metal / Porte
étagères - Métal Antracite / Estructura de
estantería - Metal Antracite



Lola's
ingredients ^{comp.} 01



LOLA o1

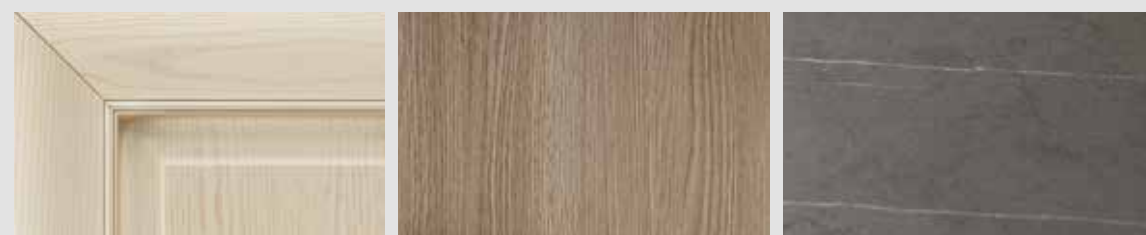

A
Frassino Decapé Bianco

B
Frassino Style

C
Unicolor Dark Stone 083

Finiture composizione 01

FRASSINO: A - Decapé Bianco -> basi, pensili, colonne e zoccoli H 12 cm / B - Frassino Style -> pannello Porta mensole / **LAMINATO:** C - Unicolor Dark Stone 083 -> piano lavoro e schienale

Composition 01 finishes

ASH: A - Decapé Bianco -> base units, wall units, tall units and plinths H 12 cm / B - Ash Style -> shelving frame panel / **LAMINATE:** C - Unicolor Dark Stone 083 -> work surface and splashback

Finitions composition 01

FRÊNE: A - Decapé Bianco -> éléments bas, éléments hauts, colonnes et socles H 12 cm / B - Frêne Style -> panneau porte étagères / **STRATIFIÉ:** C - Unicolor Dark Stone 083 -> plan de travail et crédence

Acabados composición 01

FRESNO: A - Decapé Bianco -> muebles bajos, muebles altos, columnas y zócalos H 12 cm / B - Fresno Style -> panel estructura de estantería / **LAMINADO:** C - Unicolor Dark Stone 083 -> encimera y antepecho

Pianta Lola 01

Lola 01 drawing / Plan Lola 01 / Plano Lola 01

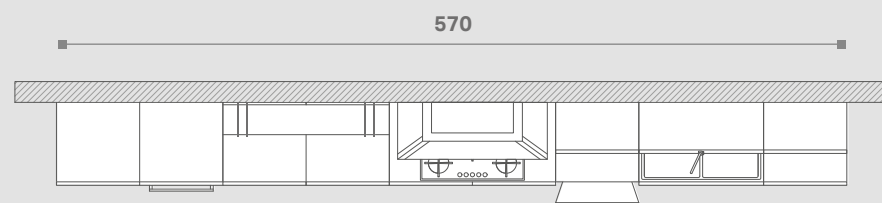

LOLA o1

Vista cucina

Kitchen view / Vue cuisine / Vista cocina

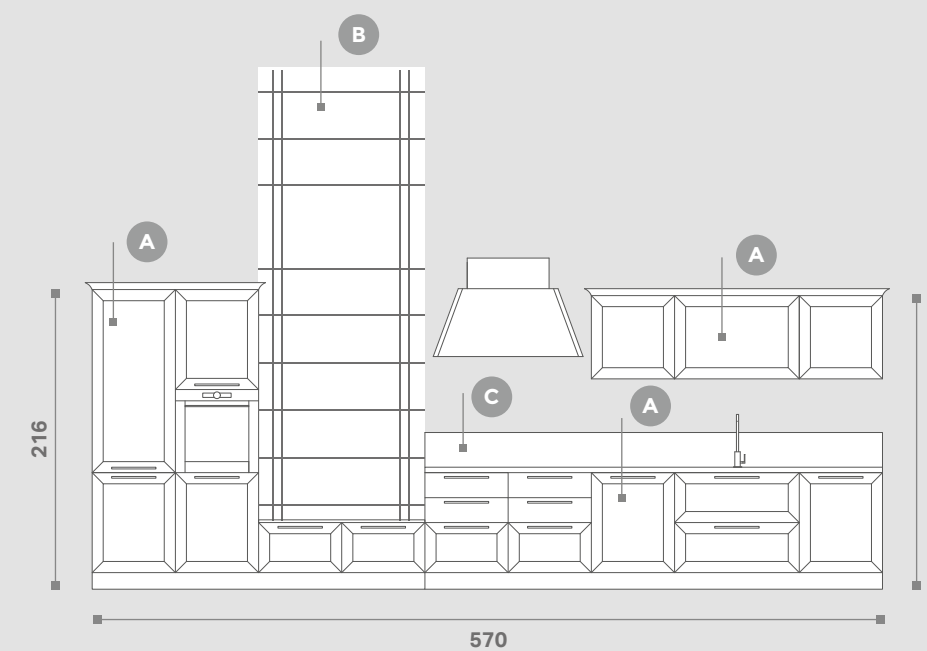

Maniglia art 561
Argento Antico
Art 561 handle
Poignée art 561
Tirador art 561

comp.

02







Il piano di lavoro e lo schienale effetto pietra rimandano a sapori tradizionali tutti da reinterpretare. L'anta bugnata caratterizza l'ambiente, creando atmosfere familiari.

The stone-effect work surface and splashback have a traditional flavour, open to new interpretations. The moulded door fronts give the space character and create a homely feel.

Le plan de travail et la crédence effet pierre renvoient aux saveurs traditionnels toutes à réinterpréter. La porte bosselée caractérise l'espace ambiant, en créant des atmosphères familiales.

La encimera y el antepecho efecto piedra evocan los sabores tradicionales, reinterpretándolos completamente. La puerta plafonada caracteriza el ambiente, creando atmósferas familiares.





Cappa "Country" -> Frassino Decapé Ghiaccio
Hood - Décapé Ghiaccio Ash / Hotte - Frêne Décapé
Ghiaccio / Campana - Fresno Decapé Ghiaccio



La cappa color ghiaccio richiama i pensili e il tavolo in una continuità cromatica che si abbina ai toni del grigio quarzo e del grigio antracite di basi, colonne e sedie.

The cool-coloured Ghiaccio hood echoes the finish of the table and wall units, creating chromatic continuity. It also matches the Grigio Quarzo and Grigio Antracite used on the base units, tall units and chairs.

La hotte coloris ghiaccio rappelle les éléments hauts et la table dans une continuité chromatique qui s'associe aux tons du grigio quarzo et du grigio antracite des éléments bas, des colonnes et des chaises.

La campana color ghiaccio reproduce el tono de los muebles altos y de la mesa en una continuidad cromática que hace juego con los tonos del grigio quarzo y del grigio antracite de muebles bajos, columnas y sillas.



Tavolo art. B570 -> Impiallacciato
Frassino Decapé Ghiaccio
Table - Veneered in Décapé Ghiaccio
Ash / Table - Plaqué Frêne Décapé
Ghiaccio / Mesa - Chapada Fresno
Décapé Ghiaccio

Sedia art. A011 -> Bianco
e Grigio Quarzo
Chair - Bianco and Grigio Quarzo /
Chaise - Bianco et Grigio
Quarzo / Silla - Bianco y Grigio Quarzo



Toni chiari e scuri si miscelano per dare vita a un ambiente elegante, ma dai tratti decisi. Gli elementi in acciaio e i punti luce danno un tocco moderno e glamour.

Dark and light tones come together to create an elegant space with bold features. The steel details and additional lighting add a chic, modern touch.

Tons clairs et foncés se mélangent pour donner naissance à un espace ambiant élégant, mais aux traits nets. Les éléments en acier et les points de lumière donnent une touche moderne et glamour.

Los tonos claros y oscuros se mezclan para dar vida a un ambiente elegante, pero de rasgos marcados. Los elementos de acero y los puntos de luz aportan un toque moderno y glamuroso.

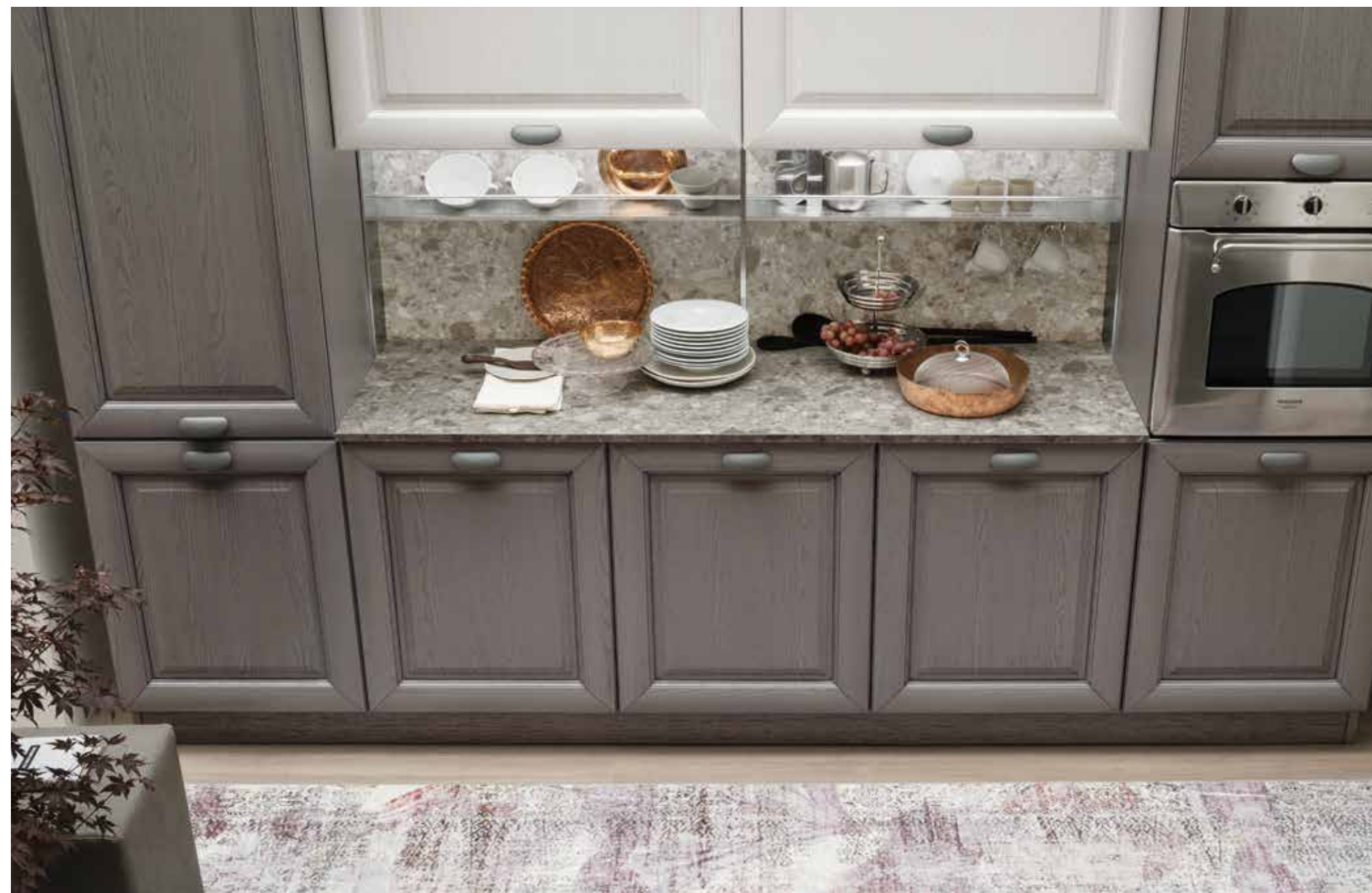

Elementi sotto pensile
"Modular" -> Acciaio
Elements under the wall
units - Steel / Éléments
sous-haut - Acier / Elementos
bajo mueble alto - Acero



La maniglia in grigio antracite dalla forma arrotondata, bella e funzionale, è un dettaglio che impreziosisce la cucina con uno stile semplice, ma ben preciso.

The Grigio Antracite handle has an elegant, rounded form that is practical, too. This detail adds value to the kitchen, in simple style that has a clear identity.

La poignée en grigio antracite à la forme arrondie, belle et fonctionnelle, est un détail qui enrichit la cuisine avec un style simple, mais bien précis.

El tirador grigio antracite de forma redondeada, hermoso y funcional, es un detalle que embellece la cocina con un estilo sencillo pero muy concreto.

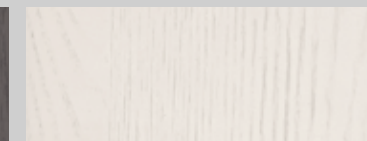
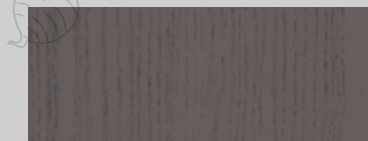

Lola's
ingredients ^{comp.} 02

LOLA 02



A
Frassino Decapé Antracite

B
Frassino Decapé Ghiaccio

C
Unicolor Sasso Grigio 078

Finiture composizione 02

FRASSINO: A - Decapé Antracite -> basi, colonne e zoccoli H 12 cm / B - Decapé Ghiaccio -> pensili / **LAMINATO:** C - Unicolor Sasso Grigio 078 -> piano lavoro e schienale

Finitions composition 02

FRÈNE: A - Décapé Antracite -> éléments bas, colonnes et socles H 12 cm / B - Décapé Ghiaccio -> éléments hauts / **STRATIFIÉ:** C - Unicolor Sasso Grigio 078 -> plan de travail et crédence

Composition 02 finishes

ASH: A - Decapé Antracite -> base units, tall units and plinths H 12 cm / B - Decapé Ghiaccio -> wall units / **LAMINATE:** C - Unicolor Sasso Grigio 078 -> work surface and splashback

Acabados composición 02

FRESNO: A - Decapé Antracite -> muebles bajos, columnas y zócalos H 12 cm / B - Decapé Ghiaccio -> muebles altos / **LAMINADO:** C - Unicolor Sasso Grigio 078 -> encimera y antepecho

Pianta Lola 02

Lola 02 drawing / Plan Lola 02 / Plano Lola 02

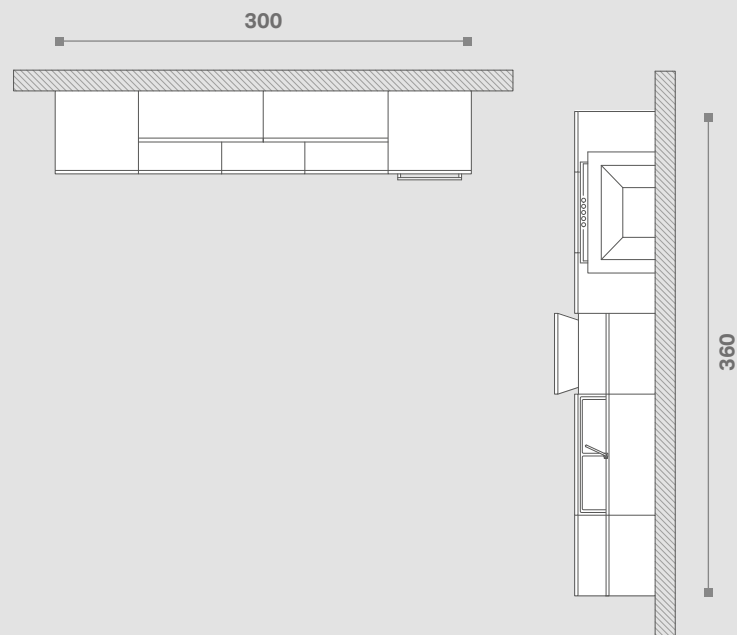

Maniglia art 541
Antracite

Art 541 handle
Poignée art 541
Tirador art 541

LOLA 02

Vista cucina

Kitchen view / Vue cuisine / Vista cocina

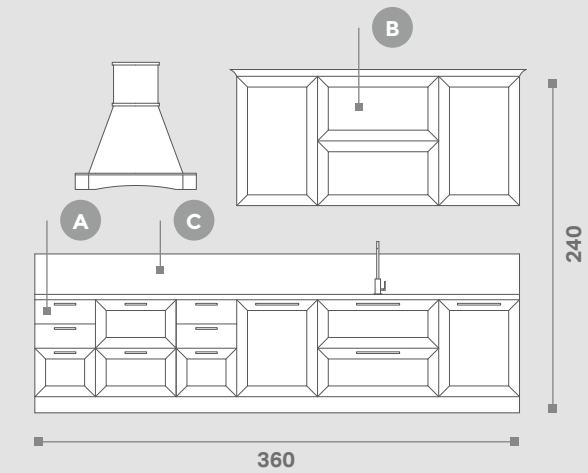

Vista colonne

Tall units view / Vue colonnes / Vista mueble columna

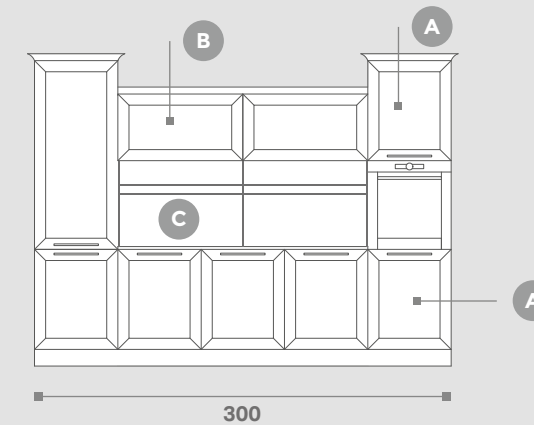

comp.

03







L'anta bugnata con inserto in vetro alleggerisce i volumi: le inglesine danno un tocco di luce alla cucina e infondono un gusto romantico a tutto l'ambiente.

Moulded door fronts featuring a glass insert lighten the look. Sash detailing brings light into the kitchen and gives the space a romantic feel.

La porte bosselée avec insert en verre allège les volumes : les petits bois donnent une touche de lumière à la cuisine et insufflent un goût romantique à tout l'espace ambiant.

La puerta con plafón de cristal aligera los volúmenes: los barrotillos confieren luminosidad a la cocina e infunden un gusto romántico a todo el ambiente.



Anta vetro satinato e inglesina -> Frassino Decapé Ghiaccio
 Frosted glass door and sash detail in Décapé Ghiaccio Ash / Porte vitrée satinée et petits bois Frêne Décapé Ghiaccio / Puerta cristal satinado y barrotillo Fresno Decapé Ghiaccio

Boiserie -> Frassino Decapé Ghiaccio
 Wood panelling - Décapé Ghiaccio Ash / Revêtement mural - Frêne Décapé Ghiaccio / Boiserie - Fresno Decapé Ghiaccio



Cappa Decò 120 -> Frassino Decapé Ghiaccio
 Decò 120 Hood - Décapé Ghiaccio Ash / Hotte
 Decò 120 - Frêne Décapé Ghiaccio / Campana
 Decò 120 - Fresno Decapé Ghiaccio

La cappa si armonizza con i pensili e dà continuità allo stile della cucina. L'anta è impreziosita da un decoro che ne enfatizza il carattere artigianale.

The hood matches the wall units to provide continuity for this kitchen style. The front is embellished with a decorative design, which gives it a hand-crafted feel.

La hotte s'harmonise avec les éléments hauts et donne continuité au style de la cuisine. La porte est enrichie par une décoration qui en souligne le caractère artisanal.

La campana hace juego con los muebles altos y aporta continuidad al estilo de la cocina. La puerta está adornada con una decoración que resalta su carácter artesanal.







Le venature del legno e del marmo si incontrano in una cucina che evoca la tradizione e il piacere di stare in famiglia in un ambiente ospitale, aperto a tutti.

Wood grain and marble veining come together in this traditional kitchen that creates a welcoming space to spend time with the family, open to all.

Les veinures du bois et du marbre se rencontrent dans une cuisine qui évoque la tradition et le plaisir d'être en famille dans un espace ambiant accueillant, ouvert à tous.

Las venas de la madera y del mármol se dan encuentro en una cocina que evoca la tradición y el placer de estar en familia en un ambiente acogedor, abierto a todos.



LOLA 03



A
Frassino Decapé Ghiaccio

B
Anta vetro con inglesina in
Frassino Decapé Ghiaccio

C
Unicolor Nero Marquinia 433

Finiture composizione 03

FRASSINO: A - Decapé Ghiaccio -> basi, colonne e zoccoli H 12 cm / B - Decapé Ghiaccio -> pensili / **LAMINATO:** C - Unicolor Nero Marquinia 433 -> piano lavoro e schienale

Composition 03 finishes

ASH: A - Decapé Ghiaccio -> base units, tall units and plinths H 12 cm / B - Decapé Ghiaccio -> wall units / **LAMINATE:** C - Unicolor Nero Marquinia 433 -> work surface and splashback

Pianta Lola 03

Lola 03 drawing / Plan Lola 03 / Plano Lola 03

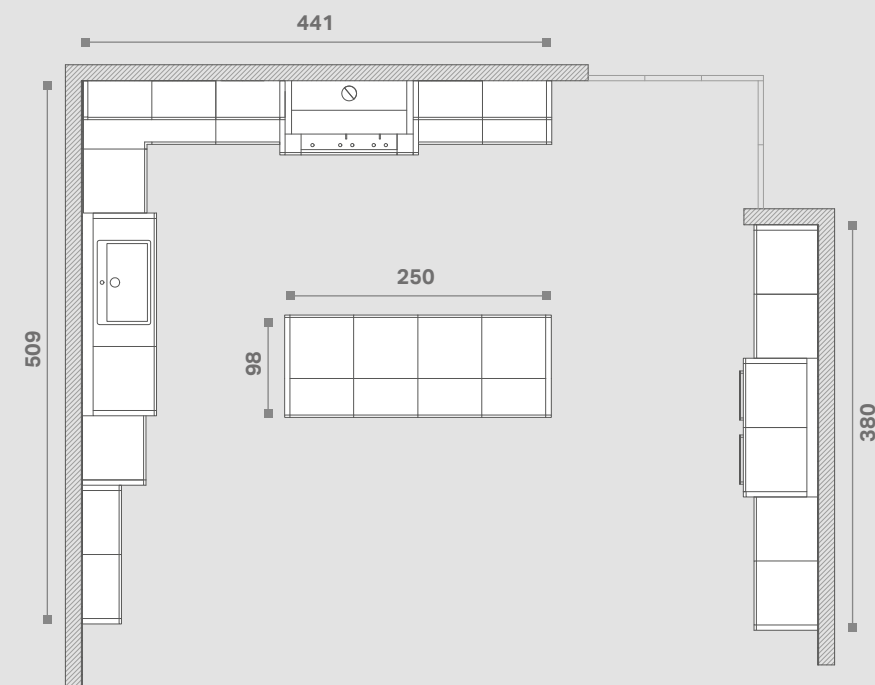

Maniglia art 1370
Nichel - Ceramica Bianca
Art 1370 handle
Poignée art 1370
Tirador art 1370

LOLA 03

Vista cucina

Kitchen view / Vue cuisine / Vista cocina

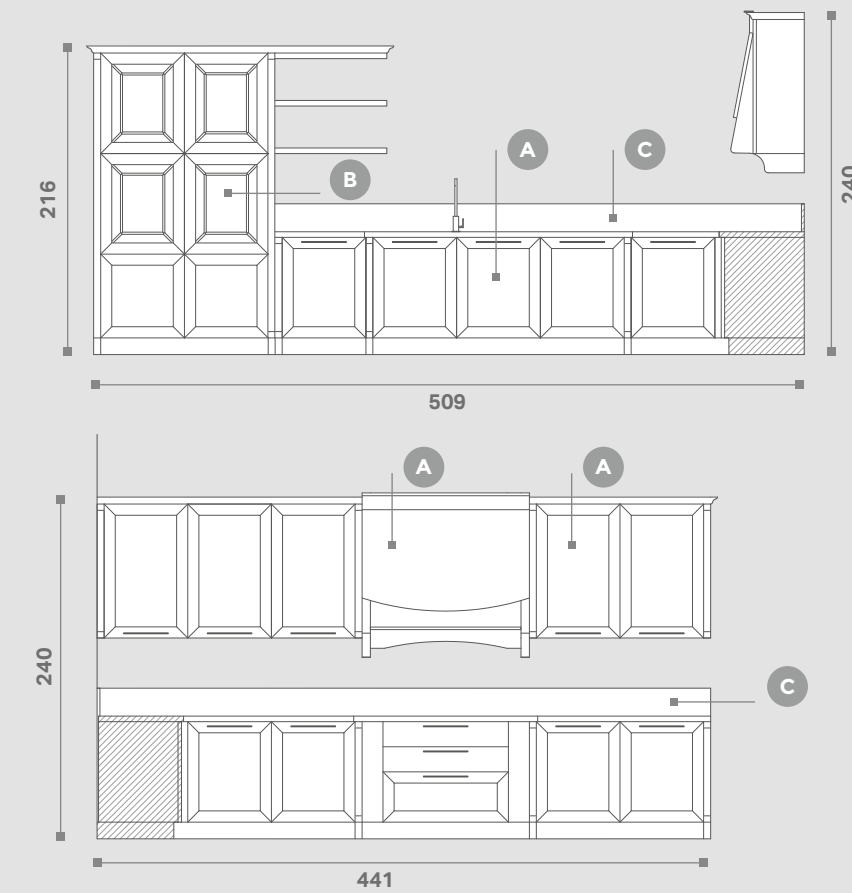

Vista colonna

Tall units view / Vue colonnes / Vista mueble columna

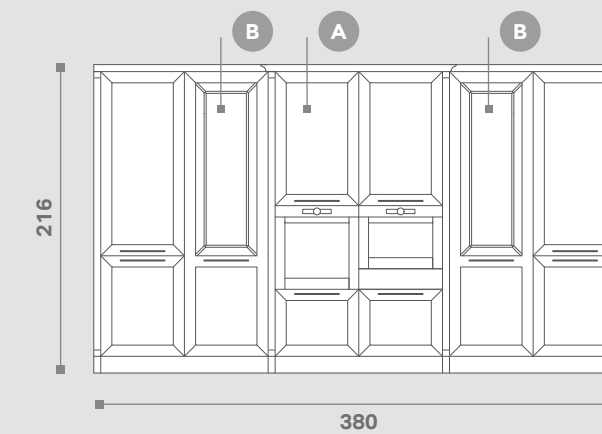

Vista isola

Island view / Vue îlot / Vista isla

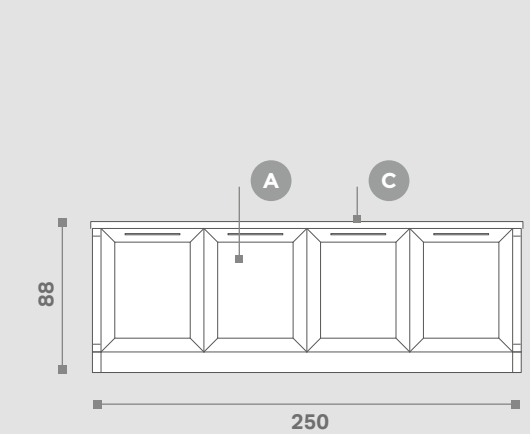

comp.

04

LOLA & PROFILI ORO





Le ante sono impreziosite da profili dorati e dettagli brillanti, come le maniglie. Il piano effetto marmo rende la cucina ancora più ricercata.

The doors are decorated with golden profiles and shiny details like the handles. The marble-effect top gives the kitchen an even more refined look.

Les portes sont enrichies par des profils dorés et des détails brillants, comme les poignées. Le plan effet marbre rend la cuisine encore plus recherchée.

Las puertas están adornadas con perfiles dorados y detalles brillantes, al igual que los tiradores. La encimera efecto mármol confiere aún más elegancia a la cocina.



Funzionalità ed estetica si danno appuntamento in cucina per creare insieme una ricetta completa nella praticità e nello stile. I profili dorati esaltano il gusto classico-chic.

Function and aesthetics come together in the kitchen to create a recipe for practicality and style. The golden profiles enhance the classic, chic look.

Fonctionnalité et esthétique se donnent rendez-vous en cuisine pour créer ensemble une recette complète dans la praticité et dans le style. Les profils dorés exaltent le goût classique-chic.

La funcionalidad y la estética se dan cita en la cocina para crear conjuntamente una receta completa en cuanto a comodidad y estilo. Los perfiles dorados acentúan el gusto clásico-chic.



Il tavolo estende lo stile della cucina ai momenti di convivialità: colazioni, pranzi e cene si svolgono all'insegna dell'eleganza e dei dettagli déco.

The table extends the kitchen style to convivial spaces to be enjoyed together: enjoy breakfast, lunch and dinner surrounded by elegant, déco details.

La table étend le style de la cuisine aux moments de convivialité : petits-déjeuners, déjeuners et diners se déroulent à l'enseigne de l'élégance et des détails déco.

La mesa extiende el estilo de la cocina a los momentos de la vida en compañía: desayunos, almuerzos y cenas interpretados con elegancia y detalles déco.





La finitura chiara e i riflessi dorati rendono la cucina particolarmente luminosa. I dettagli scuri e l'effetto marmo accentuano il carattere decorativo dell'ambiente.

The pale finish and golden reflections give the kitchen a particularly bright look. Dark details and a marble effect accentuate the decorative look of this room.

La finition claire et les reflets dorés rendent la cuisine particulièrement lumineuse. Les détails foncés et l'effet marbre accentuent le caractère décoratif de l'espace ambiant.

El acabado claro y los reflejos dorados aportan una luminosidad especial a la cocina. Los detalles oscuros y el efecto mármol subrayan el carácter decorativo del espacio.

Lola's
ingredients ^{comp.} 04



LOLA 04



A
Frassino Decapé Ghiaccio
con profili Oro

B
Quarzo Planet Mars

Finiture composizione 04

FRASSINO: A - Decapé Ghiaccio profili Oro -> basi, colonne e pensili / Decapé Ghiaccio -> elementi a giorno e zoccoli H 12 cm / **QUARZO:** B - Planet Mars -> piano lavoro e schienale

Finitions composition 04

FRÈNE: A - Decapé Ghiaccio profils Oro -> éléments bas, colonnes et éléments hauts / Decapé Ghiaccio -> éléments ouverts et socles H 12 cm / **QUARTZ:** B - Planet Mars -> plan de travail et crédence

Composition 04 finishes

ASH: A - Decapé Ghiaccio golden profiles -> base units, tall units and wall units / Decapé Ghiaccio -> open compartments and plinths H. 12 cm / **QUARZO:** B - Planet Mars -> work surface and splashback

Acabados composición 04

FRESNO: A - Decapé Ghiaccio perfiles Oro -> muebles bajos, columnas y muebles altos / Decapé Ghiaccio -> elementos abiertos y zócalos H 12 cm / **CUARZO:** B - Planet Mars -> encimera y antepecho



Maniglia art 1510
Dorata

Art 1510 handle
Poignée art 1510
Tirador art 1510

Pianta Lola 04

Lola 04 drawing / Plan Lola 04 / Plano Lola 04

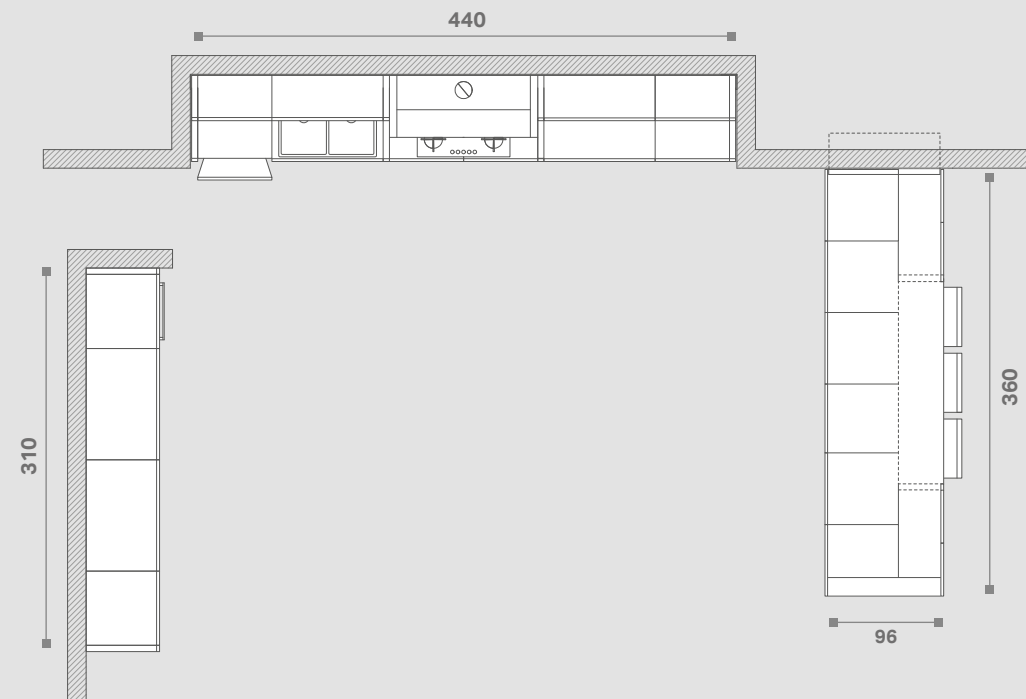

LOLA 04

Vista cucina

Kitchen view / Vue cuisine / Vista cocina

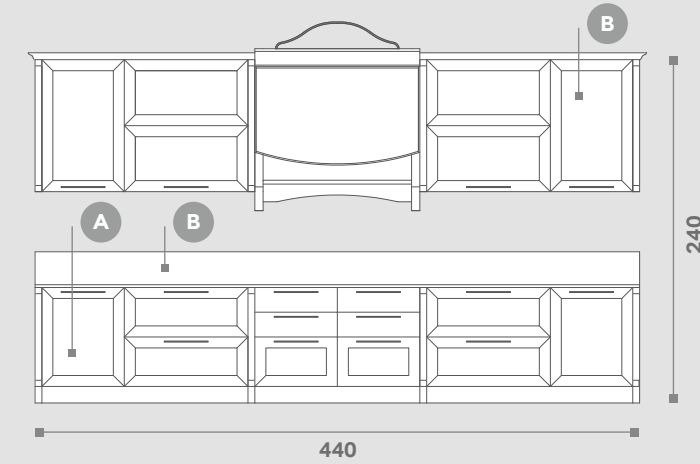

Vista isola

Island view / Vue îlot / Vista isla

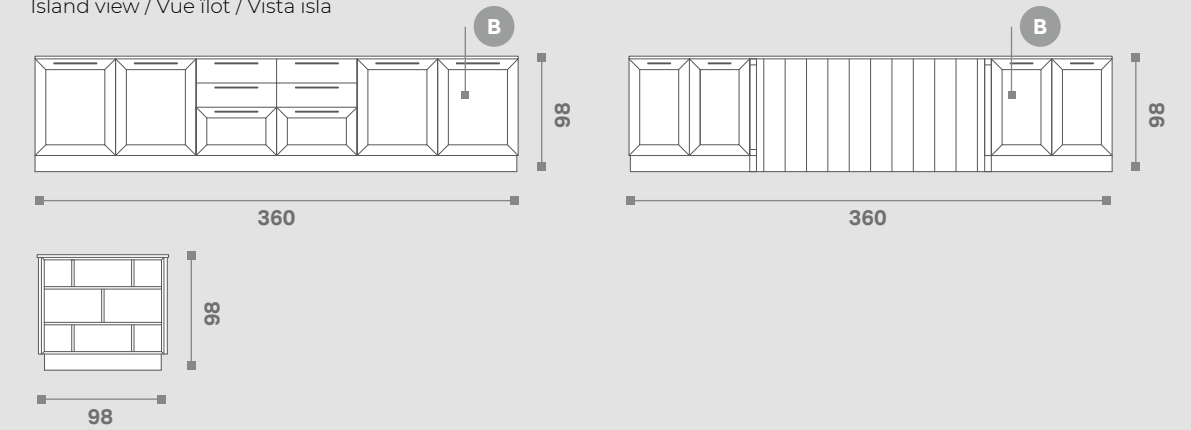

Vista colonne

Tall units view / Vue colonnes / Vista mueble columna

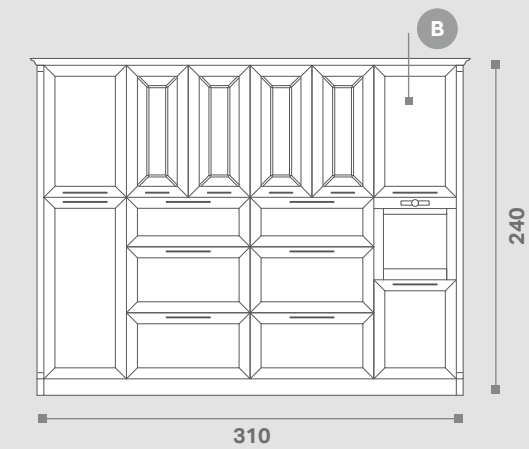

Lola Special aggiunge a una ricetta già gustosa altri ingredienti sfiziosi, per dare alla cucina nuovi sapori che esprimono il carattere e la personalità di chi la abita.

Lola Special adds extra, tasty ingredients to an already appetising recipe, bringing new flavours to the kitchen. Express your own style and personality in the kitchen.

Lola Special ajoute à une recette déjà savoureuse d'autres ingrédients appétissants, pour donner à la cuisine de nouvelles saveurs qui expriment le caractère et la personnalité de ceux qui l'habitent.

Lola Special añade a una receta sabrosa de por sí otros ingredientes caprichosos, para dar a la cocina nuevos sabores que expresan el carácter y la personalidad de quien vive en ella.

LOLA

Special

comp.

05

LOLA & MURATURA + MOSAICO

comp.

06

LOLA & DAMASCO

comp.

07

LOLA & METAL

comp.

08

LOLA & MOSAICO

comp.

05

LOLA & MURATURA
+ MOSAICO







Una cucina in muratura dall'anima artigianale, per uno spazio che esprime stile, design, ricerca dei materiali e un'attenta cura per i dettagli.

A masonry kitchen with a crafted core: create a space that expresses style, design and attention to detail, with carefully sourced materials.

Une cuisine maçonnerie à l'âme artisanale, pour un espace qui exprime style, design, recherche des matériaux et un soin attentif pour les détails.

Una cocina de obra de alma artesanal, para un espacio que transmite estilo, diseño, estudio de los materiales y un minucioso cuidado de los detalles.

Il mosaico dai disegni geometrici valorizza sia il top della cucina sia l'isola centrale, che diventa un piano d'appoggio decorativo oltre che funzionale.

A geometric mosaic design adds value to the kitchen worktops and the central island, which also provides decorative and functional surface space.

La mosaïque des dessins géométriques met en valeur aussi bien le plan de travail que l'îlot central, qui devient un plan d'appui décoratif outre que fonctionnel.

El mosaico de motivos geométricos adorna tanto la encimera de la cocina como la isla central, que se convierte en una superficie de apoyo decorativa a la par que funcional.

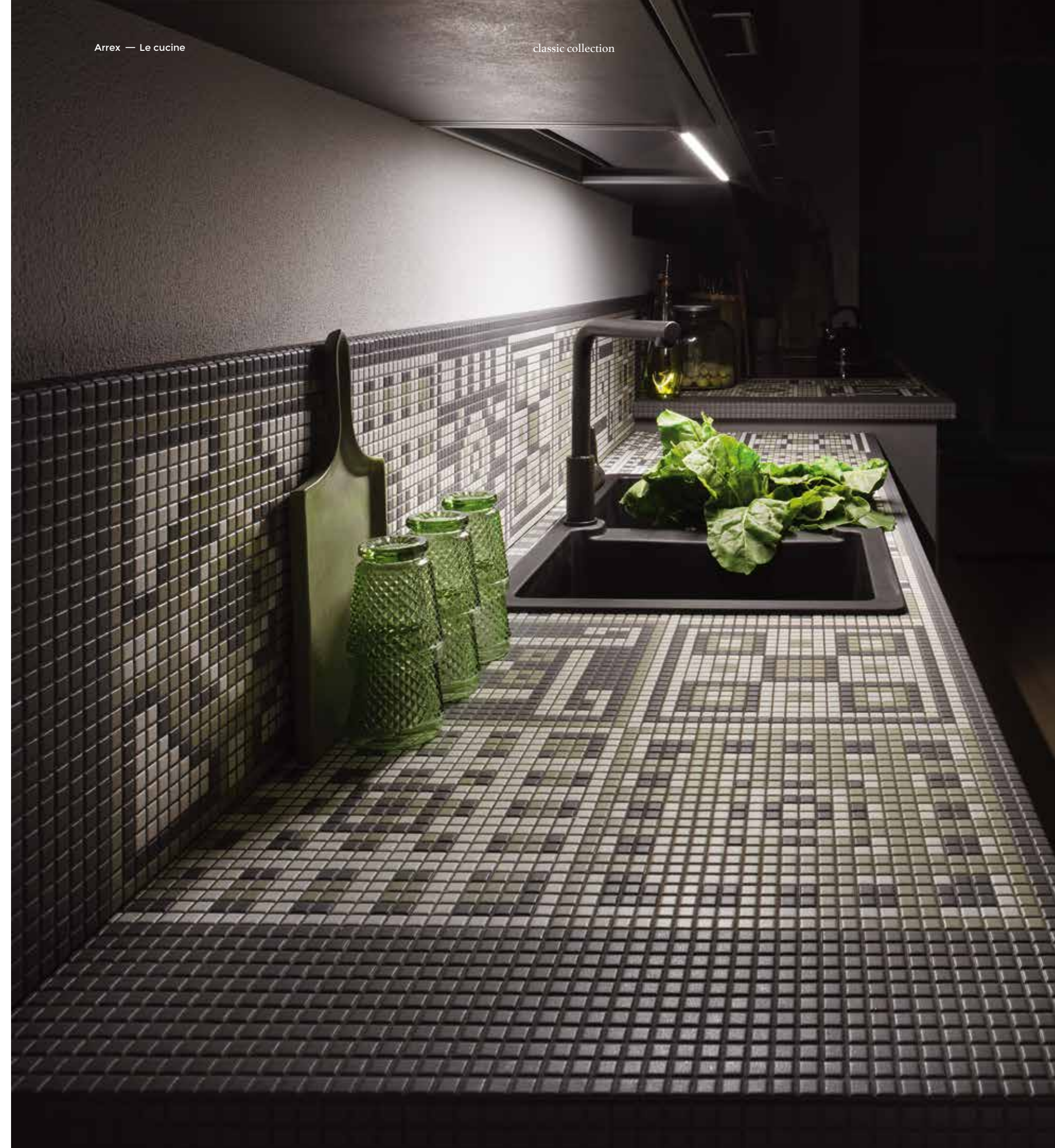



Una cucina nata sotto il segno del contrasto cromatico tra il bianco ghiaccio e il grigio antracite, dove le tessere in ceramica completano il mosaico dello stile.

This kitchen has been created out of the chromatic contrast between Bianco Ghiaccio and Grigio Antracite. The ceramic tiles complete this style mosaic.

Une cuisine née sous le signe du contraste chromatique entre le blanc ghiaccio et le grigio antracite, où les pièces en céramique complètent la mosaïque du style.

Una cocina nacida del contraste cromático entre el blanco ghiaccio y el grigio antracite, donde las teselas de cerámica completan el mosaico del estilo.





Gli elementi a giorno sono una soluzione pratica che permette di sfruttare spazi orizzontali e verticali, personalizzandoli in base ai propri gusti.

Open compartments are a practical way of making use of both vertical and horizontal spaces, and customising them to taste.

Les éléments ouverts sont une solution pratique qui permet d'exploiter des espaces horizontaux et verticaux, en les personnalisant en fonction des propres goûts.

Los elementos abiertos son una solución práctica que permite aprovechar espacios horizontales y verticales, personalizándolos según los gustos del usuario.

Lola's ingredients comp. 05



LOLA & MURATURA + MOSAICO 05



A
Frassino Decapé
Ghiaccio

B
Frassino Decapé
Antracite

C
Mosaico Ceramico

D
Muratura Sacilegraf
Antracite

Finiture composizione 05

FRASSINO: A - Decapé Ghiaccio -> basi lavello-cottura e colonne / B - Decapé Antracite -> basi isola, colonne forno, pensili e elementi a giorno / **MOSAICO:** C - Ceramico -> piano lavoro e schienale / **MURATURA:** D - Sacilegraf Antracite -> muretti, elementi sottotop e zoccoli H 10 cm

Composition 05 finishes

ASH: A - Decapé Ghiaccio -> sink/hob base units and tall units / B - Decapé Antracite -> island base units, oven / wine rack tall units, wall units and open compartments / **MOSAIC:** C - Ceramic -> work surface and splashback / **MASONRY:** D - Sacilegraf Antracite -> walls, undertop detail and plinths H 10 cm

Pianta Lola 05

Lola 05 drawing / Plan Lola 05 / Plano Lola 05

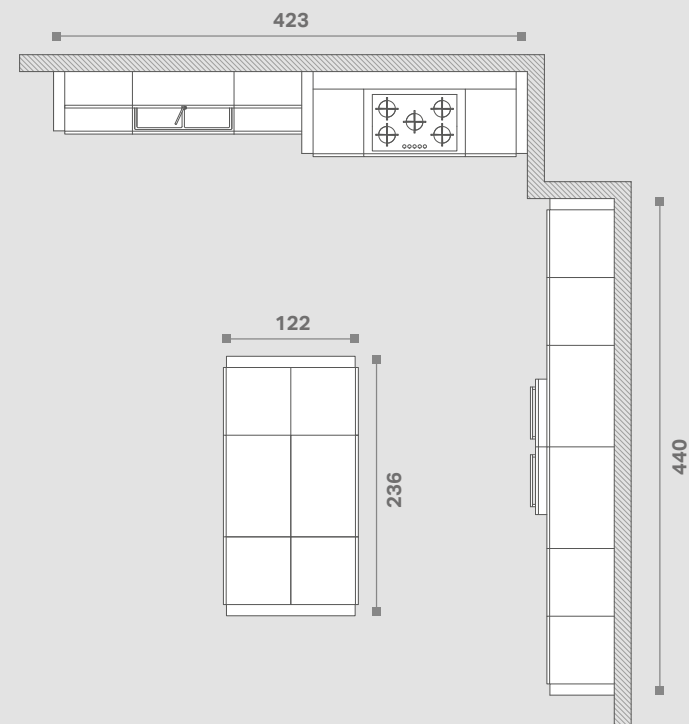

Maniglia art 531

Nichel
Art 531 handle
Poignée art 531
Tirador art 531

Finitions composition 05

FRÈNE: A - Décapé Ghiaccio -> éléments bas évier-cuisson et colonnes / B - Décapé Antracite -> éléments bas îlot, colonnes four-cave, éléments hauts et éléments ouverts / **MOSAÏQUE:** C - Céramique -> plan de travail et crédence / **MAÇONNERIE:** D - Sacilegraf Antracite -> murets, éléments sous plan et socles H 10 cm

Acabados composición 05

FRESNO: A - Decapé Ghiaccio -> muebles fregadero-placa de cocción y columnas / B - Decapé Antracite -> muebles isla, columnas horno-vinoteca, muebles altos y elementos abiertos / **MOSAICO:** C - Cerámica -> encimera y antepecho / **OBRA:** D - Sacilegraf Antracite -> muretes, elementos bajo encimera y zócalos H 10 cm

LOLA & MURATURA + MOSAICO 05

Vista cucina

Kitchen view / Vue cuisine / Vista cocina

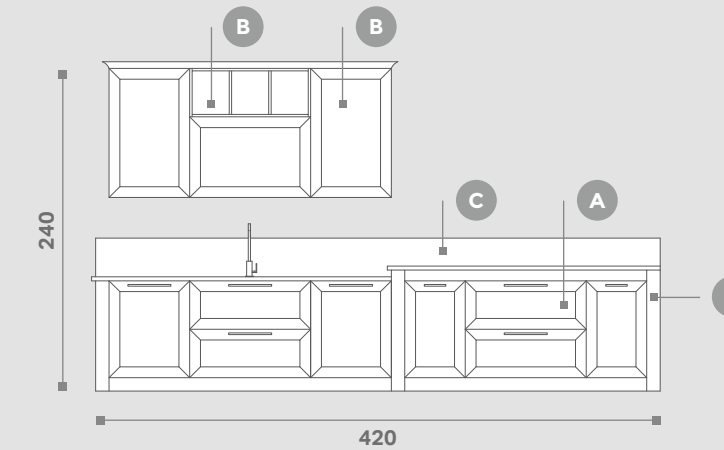

Vista colonne

Tall units view / Vue colonnes / Vista mueble columna

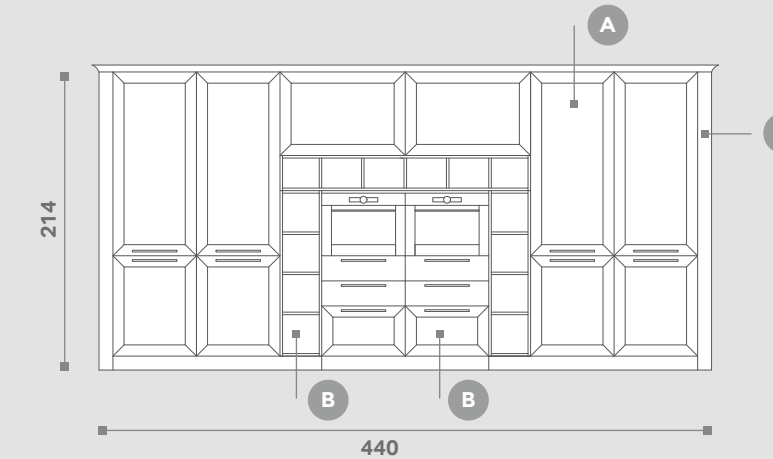

Vista isola

Island view / Vue îlot / Vista isla

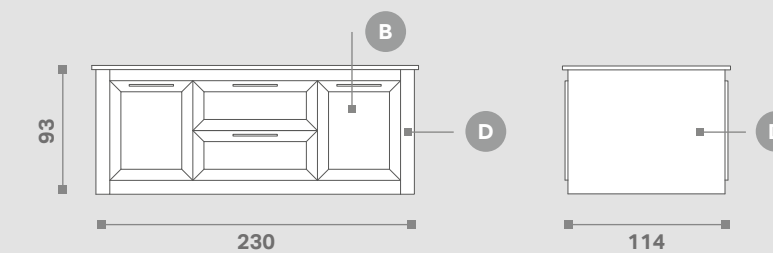

comp.
06

LOLA & DAMASCO





La matericità del legno incontra l'eleganza di una finitura damascata, per una cucina dal tratto particolare che esprime ricercatezza.

Textured wood and an elegant Damask finish combine to create a unique, refined kitchen space.

La matière du bois rencontre l'élégance d'une finition damassée, pour une cuisine au trait particulier qui exprime raffinement.

La textura material de la madera se une a la elegancia de un acabado adamascado, para una cocina de rasgos particulares que transmite sofisticación.



Elementi a giorno "Officina"
 -> Metallo Antracite
 Open-fronted compartments - Antracite metal / Éléments ouverts - Métal Antracite /
 Elementos abiertos - Metal Antracite

La finitura Damasco si inserisce tra la colonna forno e il frigo: un modulo L 30 che impreziosisce l'ambiente come un quadro d'autore su una parete.

The Damasco finish features between the tall oven and fridge units. This W. 30 panel serves as a decorative element, like a work of original art hanging on the wall.

La finition Damasco s'insère entre la colonne du four et le réfrigérateur : un module L 30 qui enrichit l'espace ambiant comme un tableau d'auteur sur un mur.

El acabado Damasco se integra entre la columna para horno y el frigorífico: un módulo L 30 que embellece el ambiente como un cuadro de autor en una pared.

Maniglia colonna art. 485 ->
Inox sistema gola piatta
Tall unit handle - Flat groove grip /
Poignée colonne - système gorge
plate / Tirador de columna - sistema
de uñero plano

Zoccoli H 12 cm -> Metallo Inox
Plinths H 12 cm - Stainless steel / Socles
H 12 cm - Inox / Zócalos H 12 cm -
Acero inoxidable



L'abbraccio tra la semplicità del legno, l'eleganza del damascato e il carattere del metallo coinvolge tutti gli elementi della cucina, compreso il tavolo: la personalità è servita.

Elegantly simple wooden units, a sophisticated Damask finish, and metal details all come together in an embrace that encompasses every element of the kitchen, including the table. Design with personality is served!

L'accolade entre la simplicité du bois, l'élégance du damassé et le caractère du métal concerne tous les éléments de la cuisine, la table comprise : la personnalité est servie.

El abrazo entre la sencillez de la madera, la elegancia del adamascado y el carácter del metal abarca todos los elementos de la cocina, incluida la mesa: la personalidad está servida.

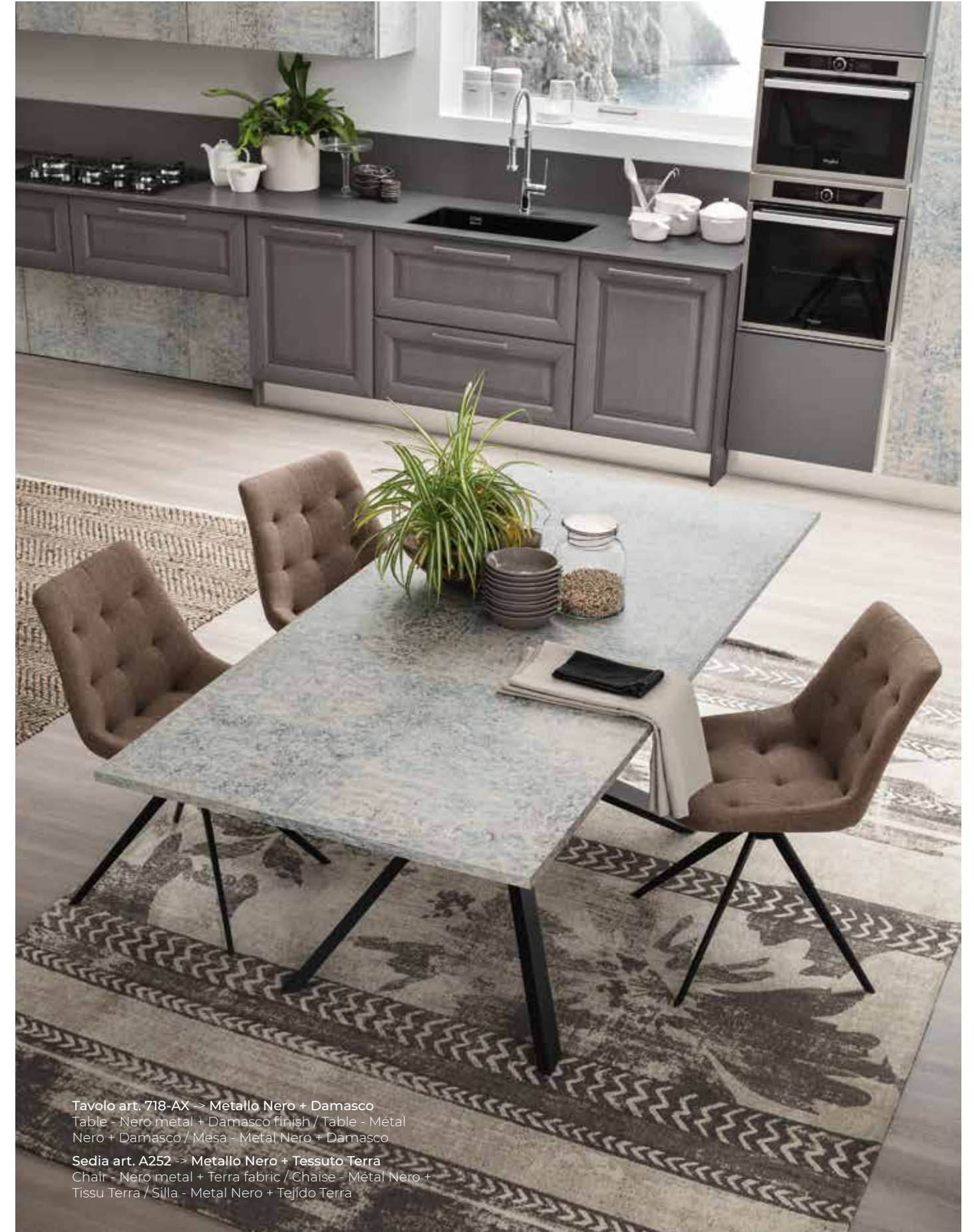

Tavolo art. 718-AX -> Metallo Nero + Damasco
Table - Nero metal + Damasco finish / Table - Métal Nero + Damasco / Mesa - Metal Nero + Damasco

Sedia art. A252 -> Metallo Nero + Tessuto Terra
Chair - Nero metal + Terra fabric / Chaise - Métal Nero + Tissu Terra / Silla - Metal Nero + Tejido Terra



Le diverse finiture e una spiccata modularità sono gli ingredienti principali di questa cucina: uno spazio personale in cui sentirsi liberi di comporre.

Different finishes and modular units are the main ingredients in this kitchen. Arrange the space freely to create a composition that is personal to you.

Les différentes finitions et une modularité prononcée sont les ingrédients principaux de cette cuisine : un espace personnel où se sentir libres de composer.

Los diversos acabados y la amplia modularidad son los ingredientes principales de esta cocina: un espacio personal en el que gozar de libertad creativa.



Lola's
ingredients comp. 06



LOLA & DAMASCO 06

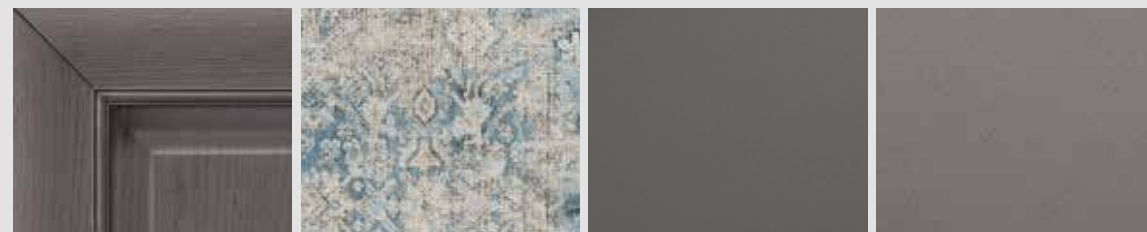

A
Frassino Decapé
Antracite

B
Lab
Damasco

C
Loft-Line
NCS S 6000 - N

D
Gres Pandora
Cenere

Finiture composizione 06

FRASSINO: A - Decapé Antracite -> basi /
DAMASCO: B -> pensili, basi living e colonna
da 30 / **NCS S 62000-N:** C -> colonne, schiena
e divisori elementi a giorno / **GRES:** D - Pandora
Cenere -> piano lavoro e schienale

Composition 06 finishes

ASH: A - Decapé Antracite -> base units / **DAMASCO:**
B -> wall units, living-room base units and tall units
30 / **NCS S 62000-N:** C -> tall units, splashback and
open-compartment dividers / **GRES:** D - Pandora
Cenere -> work surface
and splashback

Finitions composition 06

FRÊNE: A - Decapé Antracite -> éléments bas /
DAMASCO: B -> éléments hauts, éléments bas living
et colonnes de 30 / **NCS S 62000-N:** C -> colonnes,
fond et séparations éléments ouverts / **GRES:** D -
Pandora Cenere -> plan de travail et crédence

Acabados composición 06

FRESNO: A - Decapé Antracite -> muebles
bajos / **DAMASCO:** B -> muebles altos, muebles
bajos salón y columna de 30 / **NCS S 62000-N:**
C -> columnas, trasera y divisores elementos
abiertos / **GRES:** D - Pandora Cenere -> encimera
y antepecho



Maniglia art 555
Tortora

Art 555 handle
Poignée art 555
Tirador art 555

Pianta Lola 06

Lola 06 drawing / Plan Lola 06 / Plano Lola 06

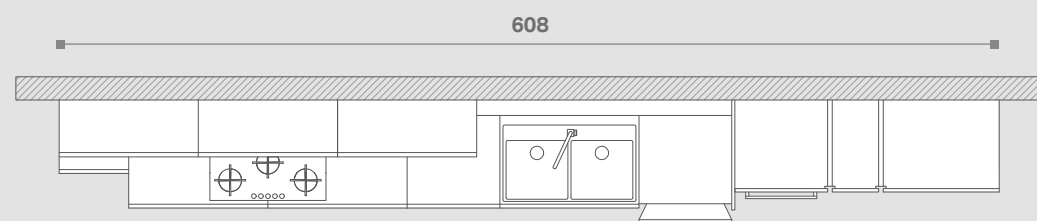

LOLA & DAMASCO 06

Vista cucina

Kitchen view / Vue cuisine / Vista cocina

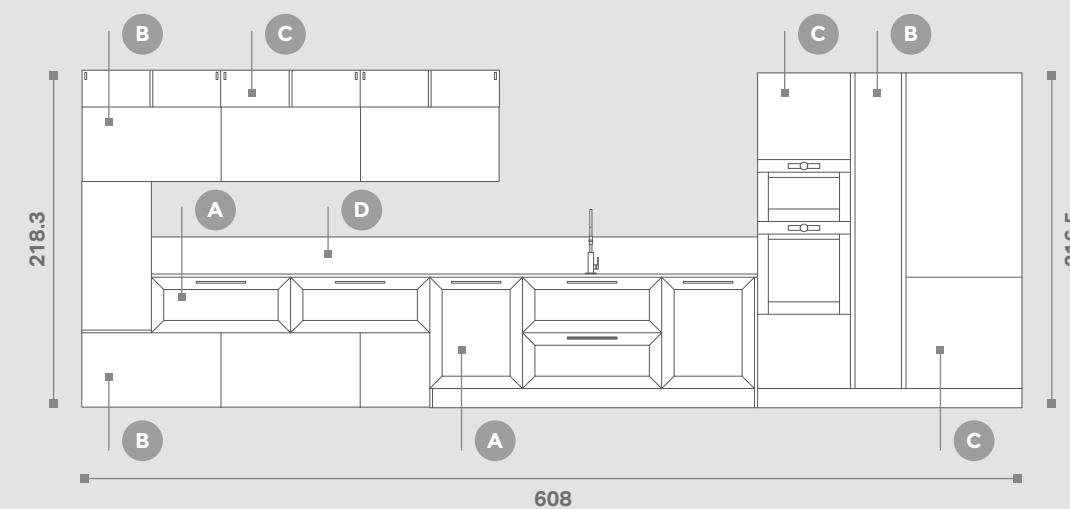

comp.

07

LOLA & METAL





Classico sotto, moderno sopra: il contrasto stilistico e materico si fa armonico in questa cucina, che esce dagli schemi per essere semplicemente sé stessa.

With traditional-style base units and modern wall units, stylistic and textural contrasts create a harmonious look in this kitchen. Think outside the box and be yourself.

Classique dessous, moderne dessus : le contraste stylistique et matérielle se fait harmonieux dans cette cuisine, qui sort des schémas pour être tout simplement elle-même.

Clásico por abajo, moderno por arriba: el contraste de estilos y materiales resulta armonioso en esta cocina, que rompe con los esquemas para ser simplemente ella misma.



Vetrine "Officina" -> Antracite
 Display units - Antracite / Vitrines - Antracite /
 Vitrinas - Antracite

Zoccoli H 12 cm -> Metallo Antracite
 Plinths H. 12 cm - Antracite metal / Socles H 12 cm -
 Métal Antracite / Zócalos H 12 cm - Metal Antracite

L'ambiente si riempie senza appesantirsi,
grazie ai moduli a giorno e agli elementi sottopensile
"Modular" con finitura titanio.

This space is packed with features
such as open compartments and
modular elements under the wall
units in a Titanio finish, without this
weighing down the design.

L'espace ambiant se remplit
sans s'alourdir, grâce aux
modules ouverts et aux
éléments sous-haut « Modular »
avec finition titanio.

El ambiente se llena sin ser
recargado, gracias a los módulos
abiertos y a los elementos bajo
mueble alto "Modular" con
acabado titanio.



**Elementi sotto pensile
"Modular" -> Titanio**
Elements under the wall units
- Titanio / Éléments sous-haut -
Titanio / Elementos bajo mueble
alto - Titanio

**Elementi a giorno "Officina" ->
Metallo Antracite**
Open-fronted compartments
- Antracite metal / Éléments
ouverts - Métal Antracite /
Elementos abiertos - Metal Antracite



L'armonia tra forme, colori e materiali crea uno spazio piacevole dove gli elementi si esaltano a vicenda come gli ingredienti di una ricetta ben riuscita.

Well-balanced shapes, colours and materials create a pleasant space in which the features all complement one another, just like the ingredients in a great recipe.

L'harmonie entre formes, coloris et matériaux crée un espace agréable où les éléments s'exaltent l'un l'autre comme les ingrédients d'une recette bien réussie.

La armonía entre formas, colores y materiales crea un espacio agradable en el que los elementos se resaltan mutuamente, como los ingredientes de una receta que ha salido bien.



Lola's
ingredients ^{comp.} 07



LOLA & METAL 07

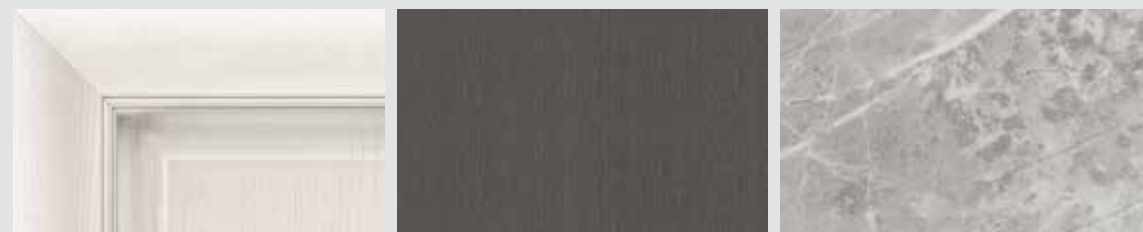

A
Frassino Decapé Ghiaccio

B
Lab Metal Piombo

C
Unicolor Grey Stone 725

Finiture composizione 07

FRASSINO: A - Decapé Ghiaccio -> basi, schiena e divisori elementi a giorno / **Lab METAL:** B - Piombo -> colonne, base living e pensili / **LAMINATO:** C - Unicolor Grey Stone 725 -> piano lavoro, fiancone e schienale

Composition 07 finishes

ASH: A - Decapé Ghiaccio -> base units, splashback and open-compartment dividers / **Lab METAL:** B - Piombo -> tall units, living-room base units and wall units / **LAMINATE:** C - Unicolor Grey Stone 725 -> work surface, large side panel and splashback

Finitions composition 07

FRÈNE: A - Décapé Ghiaccio -> éléments bas, fond et séparations éléments ouverts / **Lab MÉTAL:** B - Piombo -> colonnes, éléments bas living et éléments hauts / **STRATIFIÉ:** C - Unicolor Grey Stone 725 -> plan de travail, grand côté et crédence

Acabados composición 07

FRESNO: A - Décapé Ghiaccio -> muebles bajos, trasera y divisores elementos abiertos / **Lab MÉTAL:** B - Piombo -> columnas, mueble bajo salón y muebles altos / **LAMINADO:** C - Unicolor Grey Stone 725 -> encimera, costado y antepecho



Maniglia art 521
Antracite

Art 521 handle
Poignée art 521
Tirador art 521

Pianta Lola 07

Lola 07 drawing / Plan Lola 07 / Plano Lola 07

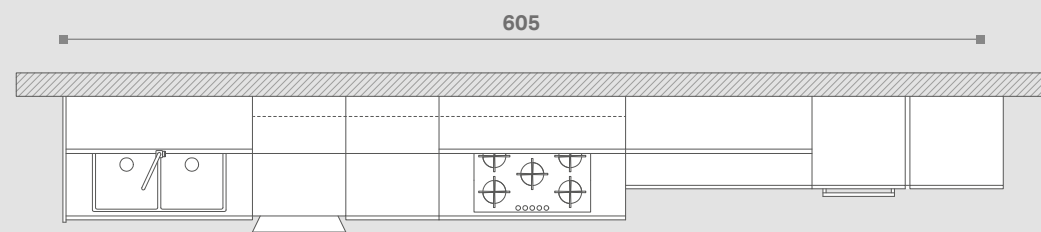

LOLA & METAL 07

Vista cucina

Kitchen view / Vue cuisine / Vista cocina

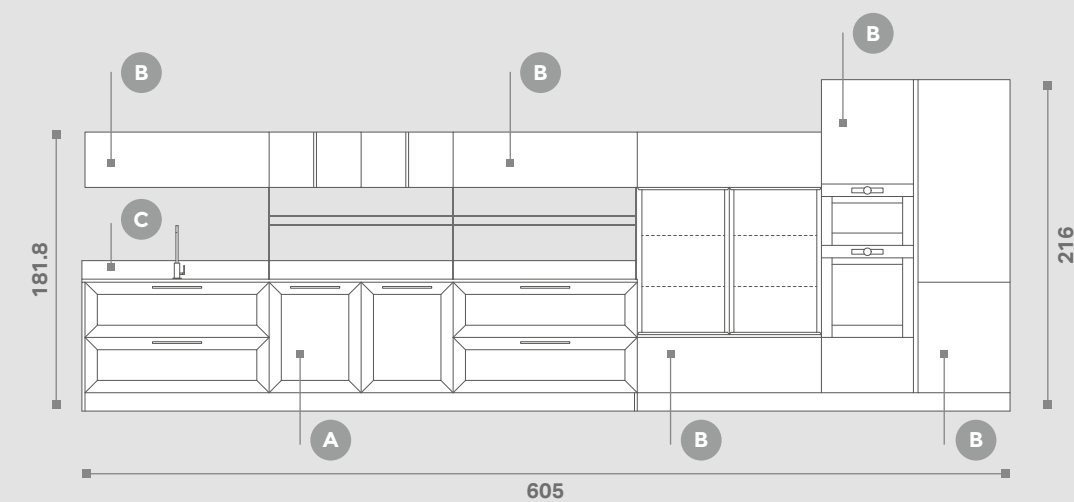

comp.
08

LOLA & MOSAICO







Il mosaico in ceramica sul piano di lavoro arreda la cucina con un tocco originale che ne definisce lo stile. Il tavolo in legno massiccio crea uno spazio accogliente.

The ceramic mosaic on the work surface gives the kitchen an original touch and a clear style. The solid-wood table creates an inviting space.

La mosaïque en céramique sur le plan de travail décore la cuisine avec une touche originale qui en définit le style. La table en bois massif crée un espace accueillant.

El mosaico de cerámica en la encimera decora la cocina con un toque original que define su estilo. La mesa de madera maciza crea un espacio acogedor.

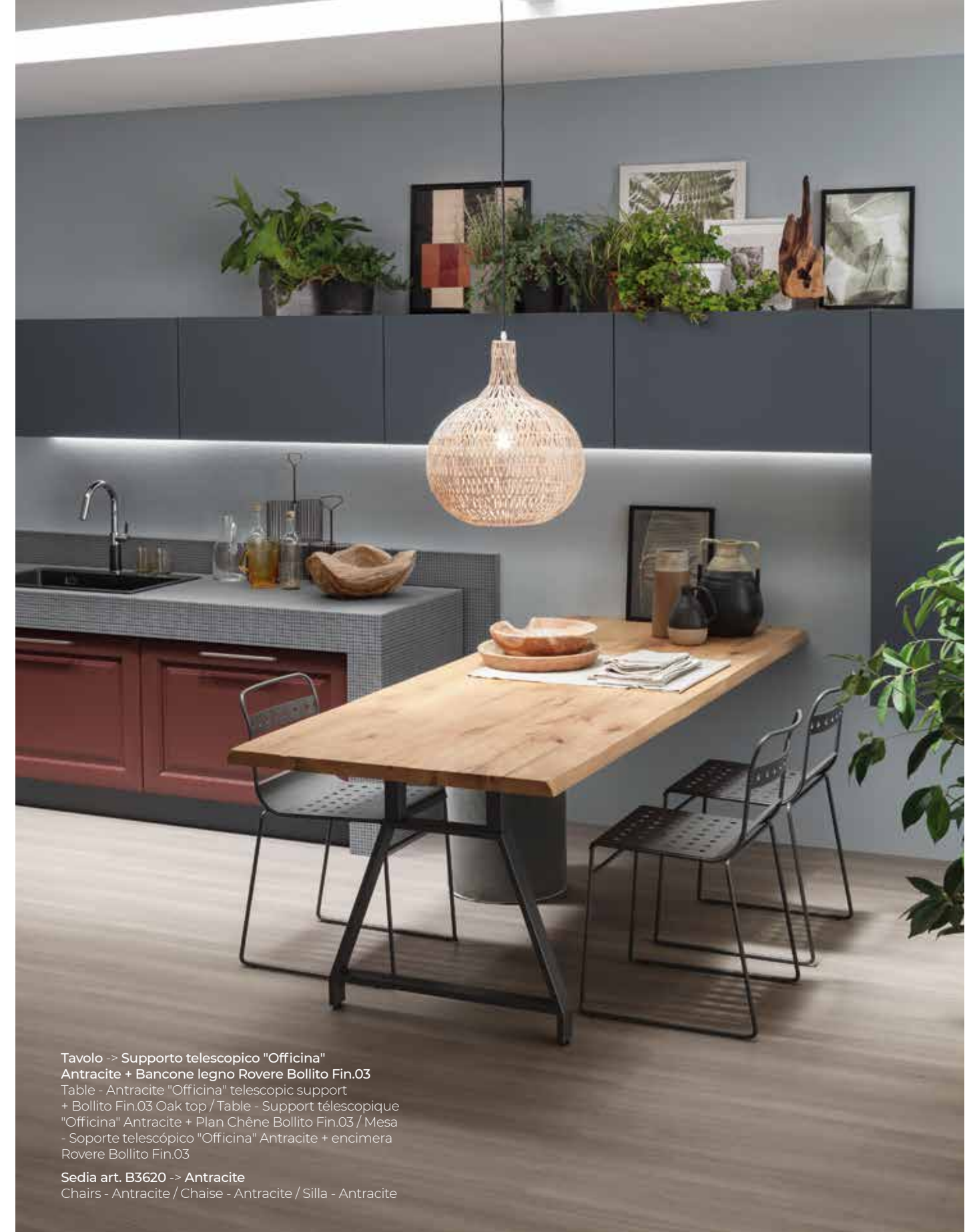

Tavolo -> Supporto telescopico "Officina"
Antracite + Bancone legno Rovere Bollito Fin.03
Table - Antracite "Officina" telescopic support
+ Bollito Fin.03 Oak top / Table - Support télescopique
"Officina" Antracite + Plan Chêne Bollito Fin.03 / Mesa
- Soporte telescópico "Officina" Antracite + encimera
Rovere Bollito Fin.03

Sedia art. B3620 -> Antracite
Chairs - Antracite / Chaise - Antracite / Silla - Antracite



Maniglia colonna art. 485 -> Laccato
Soft Grigio + sistema gola piatta
Tall unit handle - Soft Grigio lacquered
+ flat groove grip / Poignée colonne -
Laqué Soft Grigio + système gorge plate /
Tirador de columna - Laccato Soft Grigio
+ sistema de uñero plano

Elementi a giorno "Officina" -> Metallo Antracite
Open-fronted compartments - Antracite metal /
Éléments ouverts - Métal Antracite / Elementos
abiertos - Metal Antracite

Vetrine "Officina" -> Antracite
Display units - Antracite / Vitrines - Antracite /
Vitrinas - Antracite

I moduli a vista e le vetrine Officina alleggeriscono i volumi delle colonne, portando il living in cucina: il risultato è un ambiente moderno e dalla forte personalità.

The open compartments and Officina display units soften the imposing tall units, bringing an element of the living room into the kitchen. The end result is a modern space with real personality.

Les modules apparents et les vitrines Officina allègent les volumes des colonnes, en amenant le living en cuisine : le résultat est un espace ambiant moderne et à la forte personnalité.

Los módulos vistos y la vitrinas Officina aligeran los volúmenes de las columnas, introduciendo el salón en la cocina: el resultado es un ambiente moderno y de marcada personalidad.





Il mix & match tra la decorazione del mosaico in ceramica e il design delle ante bugnate in legno crea una cucina dal gusto deciso, dove condividere esperienze e passioni.

This mix-and-match effect created by the ceramic mosaic decoration and moulded wooden unit design gives the kitchen a bold look. Enjoy sharing your passions and experiences in this space.

Le mix & match entre la décoration de la mosaïque en céramique et le design des portes bosselées en bois crée une cuisine au goût prononcé, où partager des expériences et des passions.

La combinación a juego entre la decoración del mosaico de cerámica y el diseño de las puertas plafonadas de madera crea una cocina de gusto decidido, en la que compartir experiencias y pasiones.

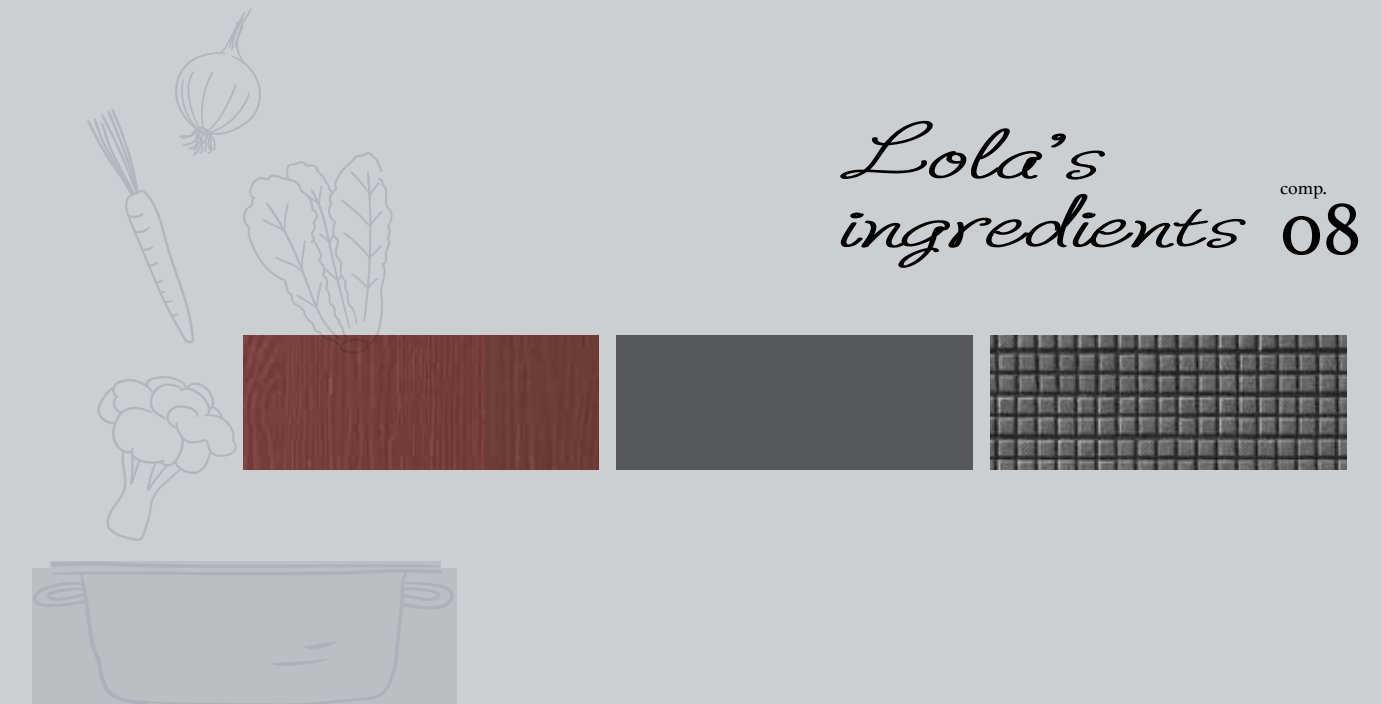

Lola's
ingredients ^{comp.} 08

LOLA & MOSAICO 08



A
Frassino Laccato opaco
NCS S 6020 – Y90R

B
Loft-Soft Grigio UV3

C
Mosaico Ceramico

Finiture composizione 08

FRASSINO LACCATO OPACO: A - NCS S 6020 – Y90R -> basi, schiena e divisori elementi a giorno / **LOFT-SOFT:** B - Grigio -> colonne, pensili e zoccoli H 12 cm / **MOSAICO:** C - Ceramico -> piano lavoro, fiancone e schienale

Finitions composition 08

FRÈNE LAQUÉ MAT : A - NCS S 6020 – Y90R -> éléments bas, fond et séparations éléments ouverts / **LOFT-SOFT :** B - Grigio -> colonnes, éléments hauts et socles H 12 cm / **MOSAÏQUE :** C - Céramique -> plan de travail, grand côté et crédence

Composition 08 finishes

MATT LACQUER ASH: A - NCS S 6020 – Y90R -> base units, splashback and open-compartment dividers / **LOFT-SOFT:** B - Grigio -> tall units, wall units and plinths H 12 cm / **MOSAIC:** C - Ceramic -> work surface, large side panel and splashback

Acabados composición 08

FRESNO LACADO MATE: A - NCS S 6020 – Y90R -> muebles bajos, trasera y divisores elementos abiertos / **LOFT-SOFT:** B - Grigio -> columnas, muebles altos y zócalos H 12 cm / **MOSAICO:** C - Cerámica -> encimera, costado y antepecho



Maniglia art 531
Nichel

Art 531 handle
Poignée art 531
Tirador art 531

Pianta Lola 08

Lola 08 drawing / Plan Lola 08 / Plano Lola 08

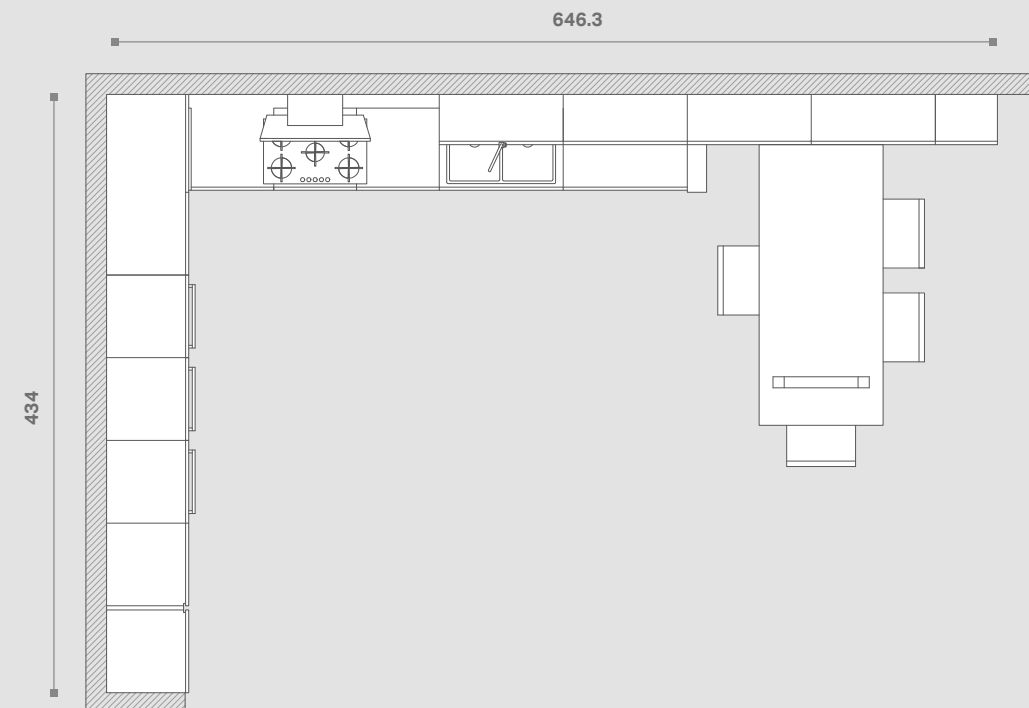

LOLA & MOSAICO 08

Vista cucina

Kitchen view / Vue cuisine / Vista cocina

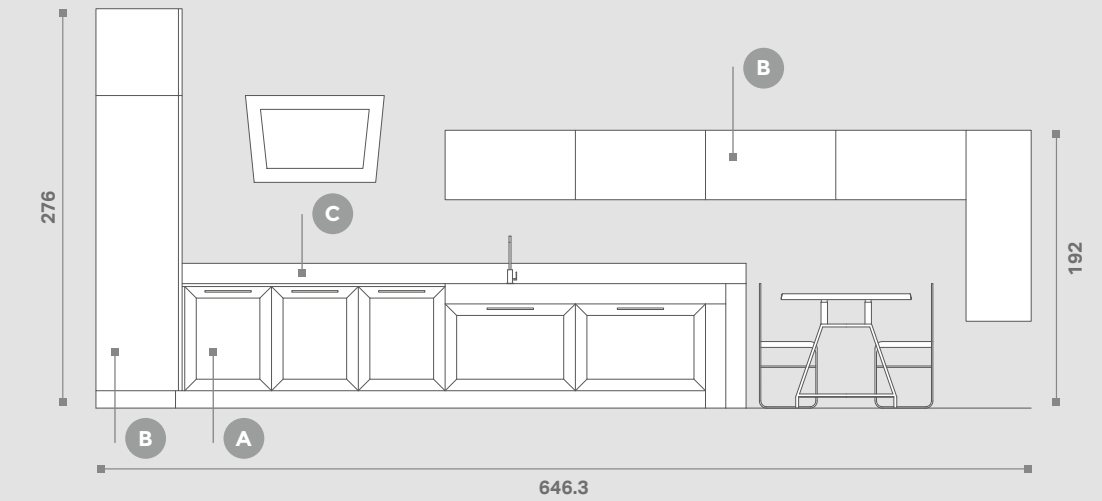

Vista colonne

Tall units view / Vue colonnes / Vista mueble columna

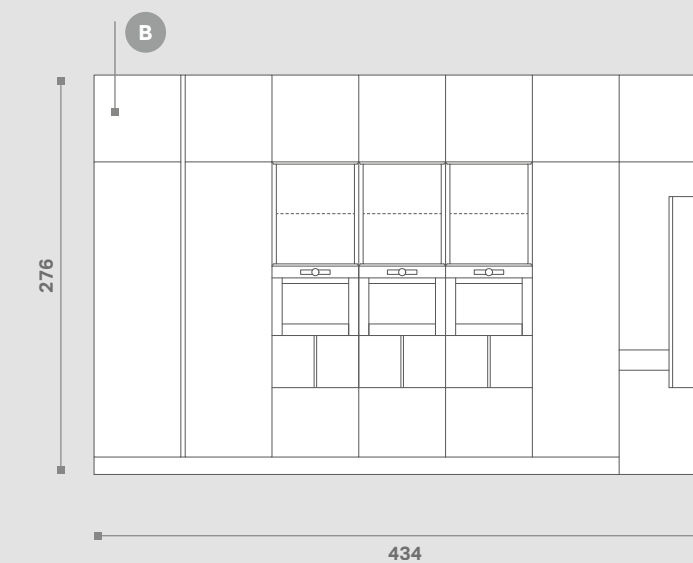

Tante finiture tutte da miscelare, per arredare con eleganza, stile, personalità. Lola è libertà di scegliere e di comporre, per essere il posto ideale in cui raccontare una storia. La vostra.

There are many finishes you can mix and match, to furnish your space elegantly, stylishly and with real personality. Lola gives you the freedom to choose and compose your own kitchen design. Create the ideal space in which to tell a story, your story.

De nombreuses finitions toutes à mélanger, pour décorer avec élégance, style, personnalité. Lola est liberté de choisir et de composer, pour être le lieu idéal où raconter une histoire. La vôtre.

Multitud de acabados que combinar, para amueblar con elegancia, estilo y personalidad. Lola es la libertad de elegir y componer, para crear el lugar ideal en el que contar una historia. La tuya.

LOLA *finishes*

LOLA
Frassino Decapé

Decapé Ash / Frêne Décapé / Fresno Decapé



Ghiaccio



Bianco



Antracite



Ghiaccio + profili Oro / Argento



◀
Disponibile in finitura Decapé Ghiaccio,
Bianco e Antracite + profili Oro / Argento)
Available in Decapé Ghiaccio, Bianco e
Antracite finishes + Golden / Silver profiles)
Disponibile en finition Decapé Ghiaccio,
Bianco et Antracite + profils Oro / Argent)
Disponibile en acabado Decapé Ghiaccio,
Bianco y Antracite + perfiles Oro / Plata)

LOLA
Frassino

Ash / Frêne / Fresno



Frassino Laccato RAL / NCS



Frassino Laccato RAL / NCS +
profili Oro / Argento

Le immagini stampate non riproducono perfettamente i colori e i toni dei nostri modelli. L'azienda si riserva di apportare tutte le modifiche ritenute necessarie al continuo miglioramento e rinnovamento dei modelli.

The printed images do not reproduce perfectly the colours and shades of our models. The company reserves the rights to make all modification necessary for the improvement and renewal of the model.

concept & graphic design
Lokomotiv

photo
Indoor

fotolito / stampa
Luce

ARREX
LE CUCINE

 **ATMA**
INDUSTRIE DEL MOBILE

ARREX LE CUCINE
31040 Mansuè (TV) Italy
Via Portobuffolè, 32

Tel. +39 0422 741331
Fax + 39 0422 741472

arrex.it _ info.arrex@arrex.it